



NE555

LINEAR INTEGRATED CIRCUIT

SINGLE TIMER

DESCRIPTION

The UTC **NE555** is a highly stable timer integrated circuit. It can be operated in both Astable and Monostable mode. With monostable operation, the time delay is precisely controlled by one external and one capacitor. With a stable operation as an oscillator the frequency and duty cycle are both accurately controlled with two external resistors and one capacitor.

FEATURES

- * High current driver capability (=200mA).
- * Adjustable duty cycle.
- * Timing from μs to hours.
- * Turn off time less than $2\mu\text{s}$.
- * Operates in both astable and monostable modes
- * General purpose frequency from 1mHz to 100kHz

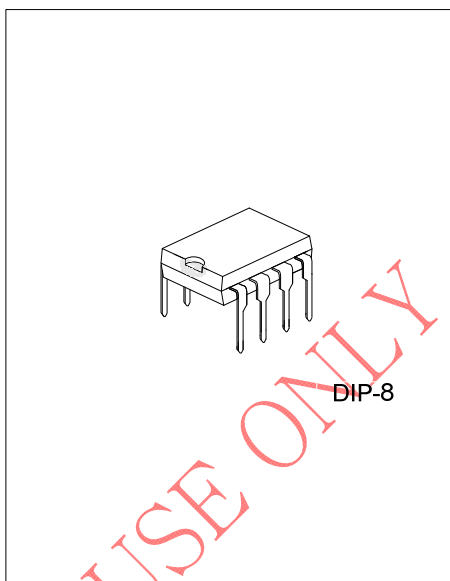

ORDERING INFORMATION

Ordering Number		Package	Packing
Lead Free	Halogen Free		
NE555L-D08-T	NE555G-D08-T	DIP-8	Tube

NE555G-D08-T	(1)Packing Type	(1) T: Tube
	(2)Package Type	(2) D08: DIP-8
	(3)Green Package	(3) G: Halogen Free and Lead Free, L: Lead Free

MARKING

DIP-8	SOP-8
<p>UTC NE555</p> <p>8 7 6 5 → Date Code</p> <p>L: Lead Free</p> <p>G: Halogen Free</p> <p>4 3 2 1 → Lot Code</p>	<p>UTC NE555G</p> <p>8 7 6 5 → Date Code</p> <p>4 3 2 1 → Lot Code</p>

■ PIN CONFIGURATION

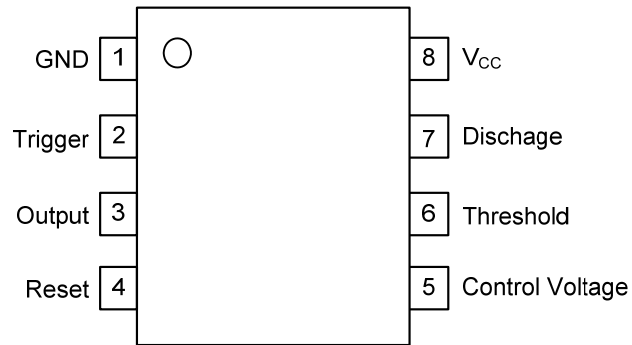

■ BLOCK DIAGRAM

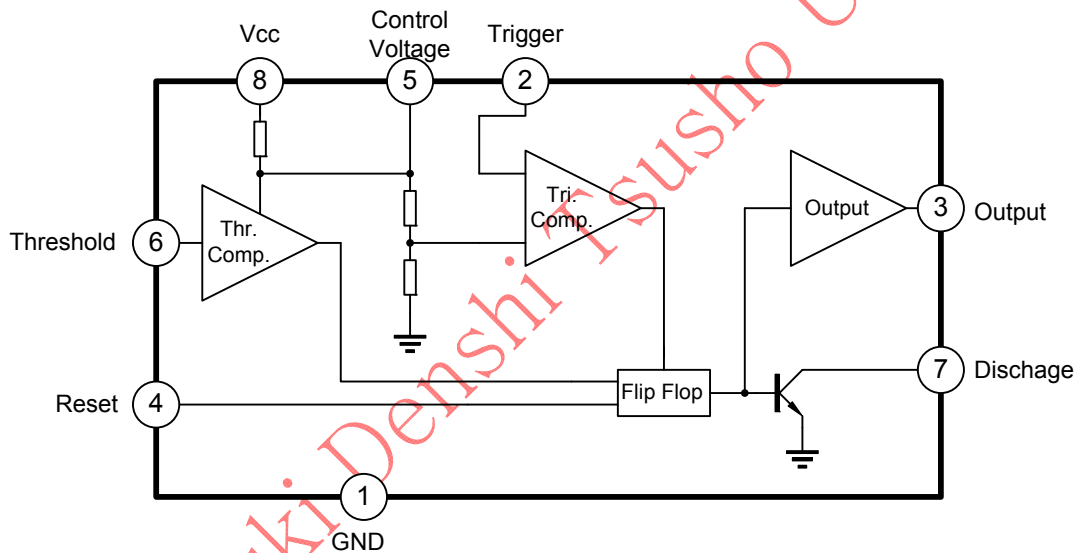

■ ABSOLUTE MAXIMUM RATINGS

PARAMETER	SYMBOL	RATINGS	UNIT
Supply Voltage	V_{CC}	16	V
Power Dissipation	P_D	600	mW
Junction Temperature	T_J	+125	°C
Operating Temperature	T_{OPR}	-20 ~ +85	°C
Storage Temperature	T_{STG}	-40 ~ +150	°C

Note: Absolute maximum ratings are those values beyond which the device could be permanently damaged. Absolute maximum ratings are stress ratings only and functional device operation is not implied.

■ ELECTRICAL CHARACTERISTICS ($V_{CC}=5 \sim 15V$, $T_A=25^\circ C$, unless otherwise specified.)

PARAMETER	SYMBOL	TEST CONDITIONS	MIN	TYP	MAX	UNIT	
Supply Voltage	V_{CC}		4.5		16	V	
Supply Current (Note 1)	I_{CC}	$V_{CC}=5V, R_L=\infty$		3	6	mA	
		$V_{CC}=15V, R_L=\infty$		7.5	15	mA	
Initial Accuracy (Note 2)	A_{CCUR}	$R_A=1k \sim 100k\Omega$		Monostable	1.0	3.0	%
				Astable	2.25		%
Drift with Temperature	$\Delta t/\Delta T$	$C=0.1\mu F$		Monostable	50		ppm/°C
				Astable	150		ppm/°C
Drift with Supply Voltage	$\Delta t/\Delta V_{CC}$			Monostable	0.1	0.5	%/V
				Astable	0.3		%/V
Control Voltage	V_C	$V_{CC}=15V$	9.0	10.0	11.0	V	
		$V_{CC}=5V$	2.6	3.33	4.0	V	
Threshold Voltage	V_{TH}	$V_{CC}=15V$		10.0		V	
		$V_{CC}=5V$		3.33		V	
Threshold Current (Note 3)	I_{TH}			0.1	0.25	μA	
Trigger Voltage	V_{TR}	$V_{CC}=5V$	1.1	1.67	2.2	V	
		$V_{CC}=15V$	4.5	5	5.6	V	
Trigger Current	I_{TR}	$V_{TR}=0$		0.01	2.0	μA	
Reset Voltage	V_{RST}		0.4	0.7	1.0	V	
Reset Current	I_{RST}			0.1	0.4	mA	
Low Output Voltage	V_{OL}	$V_{CC}=15V$					
		$I_{SINK}=10mA$		0.06	0.25	V	
		$I_{SINK}=50mA$		0.3	0.75	V	
		$V_{CC}=5V$					
High Output Voltage	V_{OH}	$I_{SINK}=5mA$		0.05	0.35	V	
		$V_{CC}=15V$					
		$I_{SOURCE}=200mA$		12.5		V	
		$I_{SOURCE}=100mA$	12.75	13.3		V	
		$V_{CC}=5V, I_{SOURCE}=100mA$	2.75	3.3		V	
Rise Time of Output	t_R			100		ns	
Fall Time of Output	t_F			100		ns	
Discharge Leakage Current	I_{LKG}			20	100	nA	

Notes: 1. Supply current when output high typically 1mA less at $V_{CC}=5V$.

2. Tested at $V_{CC}=5.0V$ and $V_{CC}=15V$.

3. This will determine the maximum value of R_A+R_B for 15V operation, The maximum total is $R=20M\Omega$, and for 5V operation the maximum total is $R=6.7M\Omega$.

TYPICAL APPLICATION CIRCUIT

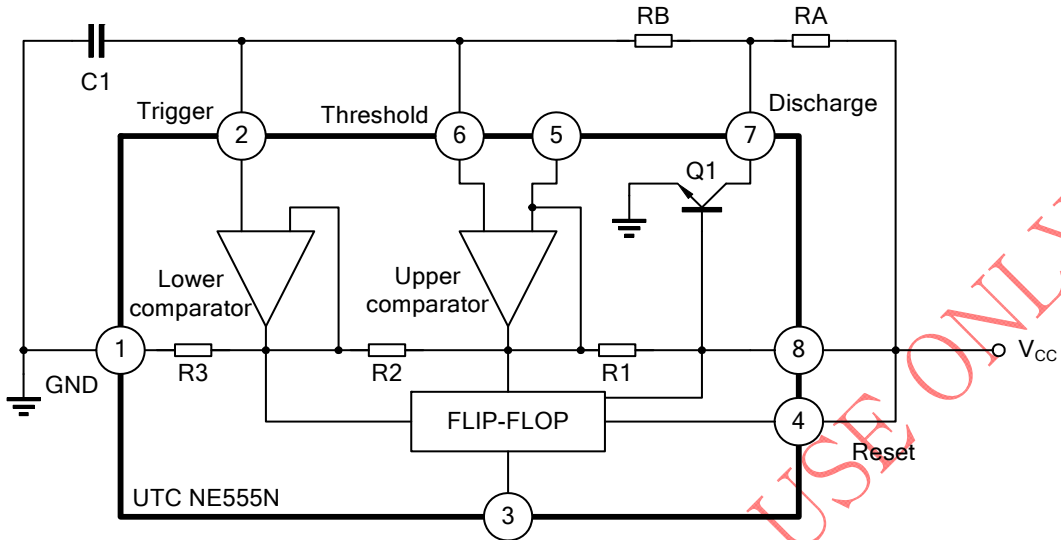

FOR Akizuki Denshi Tsusho USE ONLY

■ TYPICAL APPLICATION NOTES

The application circuit shows astable mode configuration.

Pin 6 (Threshold) is tied to Pin 2 (Trigger) and Pin 4 (reset) is tied to V_{CC} (Pin 8). The external capacitor C1 of Pin 6 and Pin 2 charges through R_A , R_B and discharges through R_B only. In the internal circuit of UTC **NE555N** , one input of the upper comparator is at voltage of $2/3V_{CC}$ ($R_1=R_2=R_3$), another input is connected to Pin 6. As soon as C1 is charging to higher than $2/3V_{CC}$, transistor Q1 is turned ON and discharge C1 to collector voltage of transistor Q1. Therefore, the flip-flop circuit is reset and output is low. One input of lower comparator is at voltage of $1/3V_{CC}$, discharge transistor Q1 turn off and C1 charges through R_A and R_B . Therefore, the flip-flop circuit is set output high.

That is, when C1 charges through R_A and R_B , output is high and when C1 discharge through R_B , output is low. The charge time (output is high) t_1 is $0.693(R_A+R_B) C_1$ and the discharge time (output is low) T_2 is $0.693 R_B \times C_1$.

$$\ln \frac{V_{CC} - \frac{1}{3} V_{CC}}{V_{CC} - \frac{2}{3} V_{CC}} = 0.693$$

$$T_1 = 0.693 \times (R_A + R_B) \times C_1$$

$$T_2 = 0.693 \times R_B \times C_1$$

Thus the total period time T is given by

$$T = T_1 + T_2 = 0.693(R_A + 2R_B) \times C_1.$$

Then the frequency of astable mode is given by

$$f = \frac{1}{T} = \frac{1.44}{(R_A + 2R_B) \times C_1}$$

The duty cycle is given by

$$\text{D.C.} = \frac{T_2}{T} = \frac{R_B}{R_A + 2R_B}$$

TYPICAL CHARACTERISTICS

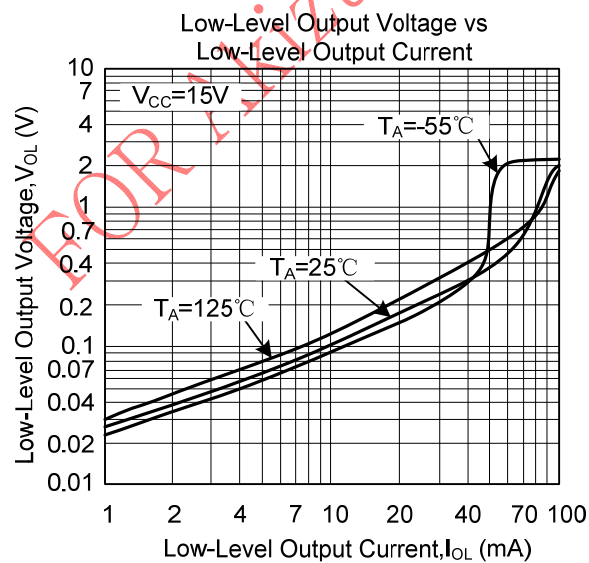
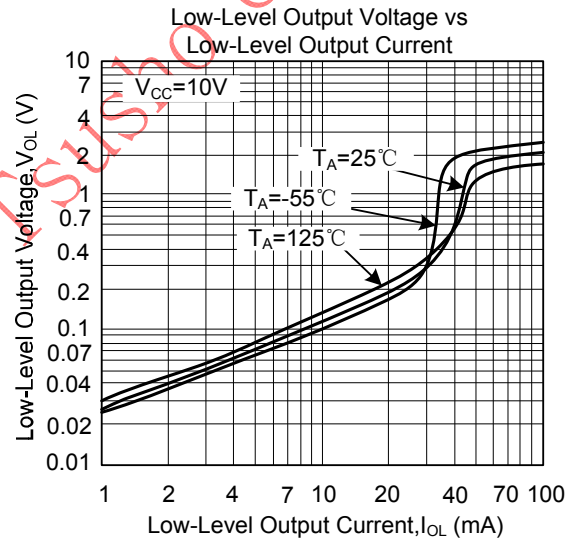
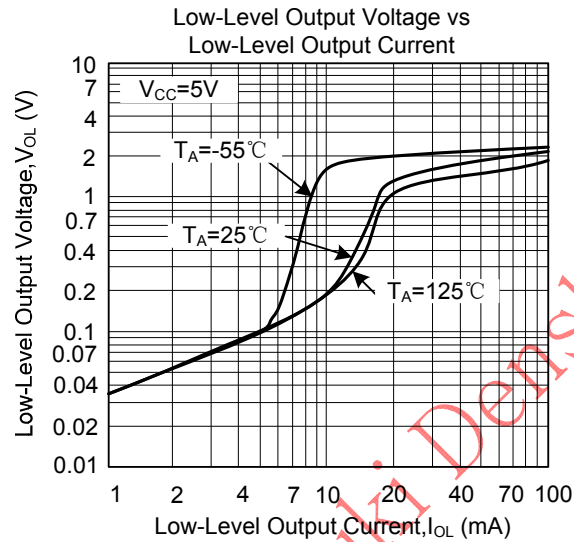
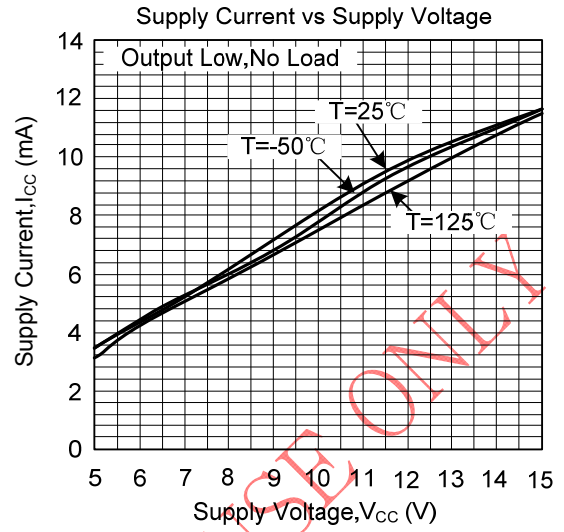
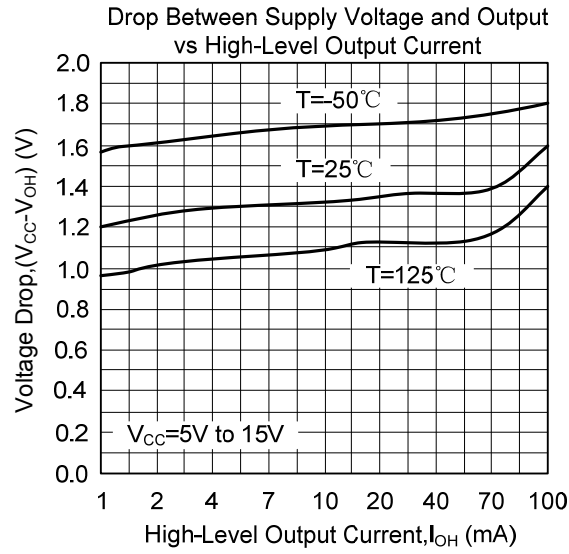

FOR Akizuki Denshi Tsusho USE ONLY

UTC assumes no responsibility for equipment failures that result from using products at values that exceed, even momentarily, rated values (such as maximum ratings, operating condition ranges, or other parameters) listed in products specifications of any and all UTC products described or contained herein. UTC products are not designed for use in life support appliances, devices or systems where malfunction of these products can be reasonably expected to result in personal injury. Reproduction in whole or in part is prohibited without the prior written consent of the copyright owner. UTC reserves the right to make changes to information published in this document, including without limitation specifications and product descriptions, at any time and without notice. This document supersedes and replaces all information supplied prior to the publication hereof.